

## **Alternators LSA 51.2 - 4 Pole**

**1860 ... 2250 kVA - 50 Hz / 2230 ... 2700 kVA - 60 Hz**

**Electrical and mechanical data**

### SPECIALLY ADAPTED FOR GENSET APPLICATIONS

The LSA 51.2 alternator is designed to be suitable for typical generator set applications, such as: backup, base production, cogeneration, marine applications, rental, telecommunications, etc.

### COMPLIANT WITH INTERNATIONAL STANDARDS

The LSA 51.2 alternator conforms to the main international standards and regulations:

IEC 60034, NEMA MG 1.22, ISO 8528/3, CSA, UL 1446, UL 1004B on request, marine regulations, etc.

It can be integrated into a CE marked generator.

The LSA 51.2 is designed, manufactured and marketed in an ISO 9001 and ISO 14001 environment.

### TOP OF THE RANGE ELECTRICAL PERFORMANCE

- Class H insulation.
- Standard 6-wire winding, 2/3 pitch, type no. 6S.
- Voltage range 50 Hz : 380V - 400V - 415V - 440 V.
- Voltage range 60 Hz : 380V - 416V - 440V - 480V.
- Ability to reconnect : 50 Hz : 220V - 230V - 240V / 60 Hz : 220 V - 240 V : consult factory.
- Other voltages are possible with optional adapted windings :
  - 50 Hz : 440 V (no. 7S), 500 V (no. 9S), 600 V (no. 22S or 23S), 690 V (no. 10S or 52S)
  - 60 Hz : 380 V and 416 V (no. 8S), 600 V (no. 9S).
- High efficiency and motor starting capacity.
- Total harmonic content < 3,5 %.
- R 791 interference suppression conforming to standard EN 55011 group 1 class B standard for the European zone (CE marking).

### EXCITATION AND REGULATION SYSTEM SUITED TO THE APPLICATION

The LSA 51.2 can be supplied with AREP or PMG excitation system, according to the alternator specification.

Standard excitation system is AREP with R 449 A.V.R.

Excitation system			Regulation options				
Volage regulator	AREP	PMG	C.T. Current transformer for paralleling	R 726 Mains paralleling	R 731 3 Phase sensing	R 734 3 Phase sensing for unbalanced mains paralleling	P Remote voltage potentiometer
R 449	Std	Option	√	√	√	√	√
DECS 100 (digital)	Option	Option	√	included	included	Na	√

Voltage regulator accuracy  $\pm 0.5\%$ . - √ : adaptation possible - Na : not achievable.

### PROTECTION SYSTEM SUITED TO THE ENVIRONMENT

- The LSA 51.2 is IP 23.
- Standard winding protection for clean environments with relative humidity  $\leq 95\%$ , including indoor marine environments.
- Options:
  - Filters on air inlet and air outlet (IP 44).
  - Winding protections for harsh environments and relative humidity greater than 95%.
  - Space heaters.
  - Thermal RTD protection for winding.

### REINFORCED MECHANICAL STRUCTURE USING FINITE ELEMENT MODELLING

- Compact and rigid assembly to better withstand genset or engine vibrations.
- Steel frame.
- Cast iron flanges and shields.
- Twin-bearing and single-bearing versions designed to be suitable for most engines on the market.
- Half-key balancing.
- Regreasable bearings.

### ACCESSIBLE TERMINAL BOX PROPORTIONED FOR OPTIONAL EQUIPMENT

- Easy access to the voltage regulator and to the connections.
- Possible incorporation of accessories for paralleling, protection and measurement.
- DECS 100 digital A.V.R. upgrade, including paralleling with the mains and 3 phase sensing.

## Common data

Insulation class	<b>H</b>	Excitation system	<b>A R E P + PMI or PMG</b>
Winding pitch	<b>2/3 (n° 6S)</b>	A.V.R. model	<b>R 449</b>
Terminals	<b>6</b>	Voltage regulation (*)	<b>± 0,5 %</b>
Drip proof	<b>IP 23</b>	Sustained short-circuit current	<b>300% (3 IN) : 10s</b>
Altitude	<b>≤ 1000 m</b>	Total harmonic (**) TGH / THC	<b>&lt; 3.5 %</b>
Overspeed	<b>2250 min-1</b>	Waveform : NEMA = TIF - (**)	<b>&lt; 50</b>
Air flow	<b>1,8 m³/s (50 Hz) - 2,2 m³/s (60 Hz)</b>	Wave form : C.E.I. = FHT - (**)	<b>&lt; 2 %</b>

(\*) Steady state duty. (\*\*) Total harmonic content line to line, at no load or full rated linear and balanced load.

## Ratings 50 Hz - 1500 R.P.M.

kVA / kW - P.F. = 0,8																	
Duty / T° C		Continuous duty / 40 °C								Stand-by / 40 °C				Stand-by / 27 °C			
Class / T° K		H / 125° K				F / 105° K				H / 150° K				H / 163° K			
Phase		3 ph.								3 ph.				3 ph.			
Y		380V	400V	415V	440V	380V	400V	415V	440V	380V	400V	415V	440V	380V	400V	415V	440V
Δ*		220V	230V	240V		220V	230V	240V		220V	230V	240V		220V	230V	240V	
<b>LSA 51.2 S55</b>	kVA	<b>1860</b>			1674		1696		1527		1953		1758		<b>2046</b>		1841
	kW	<b>1488</b>			1339		1357		1222		1562		1406		<b>1637</b>		1473
<b>LSA 51.2 M60</b>	kVA	<b>2050</b>			1845		1870		1683		<b>2153</b>		1937		<b>2255</b>		2030
	kW	<b>1640</b>			1476		1496		1346		1722		1550		<b>1804</b>		1624
<b>LSA 51.2 L70</b>	kVA	<b>2160</b>			1944		1970		1773		2268		2041		<b>2376</b>		2138
	kW	<b>1728</b>			1555		1576		1418		1814		1633		<b>1901</b>		1710
<b>LSA 51.2 VL85</b>	kVA	<b>2250</b>			2025		2052		1847		2363		2126		<b>2475</b>		2228
	kW	<b>1800</b>			1620		1642		1478		1890		1701		<b>1980</b>		1782

Δ\* : Consult factory

## Ratings 60 Hz - 1800 R.P.M.

kVA / kW - P.F. = 0,8																	
Duty / T° C		Continuous duty / 40 °C								Stand-by / 40 °C				Stand-by / 27 °C			
Class / T° K		H / 125° K				F / 105° K				H / 150° K				H / 163° K			
Phase		3 ph.								3 ph.				3 ph.			
Y		380V	416V	440V	480V	380V	416V	440V	480V	380V	416V	440V	480V	380V	416V	440V	480V
Δ*		220V	240V			220V	240V			220V	240V			220V	240V		
<b>LSA 51.2 S55</b>	kVA	<b>1860</b>	2019	2135	<b>2230</b>	1696	1841	1947	2034	1953	2119	2242	2342	2046	2220	2348	<b>2453</b>
	kW	<b>1488</b>	1615	1708	<b>1784</b>	1357	1473	1558	1627	1562	1695	1794	1874	1637	1776	1878	<b>1962</b>
<b>LSA 51.2 M60</b>	kVA	<b>2050</b>	2225	2353	<b>2460</b>	1870	2029	2146	2244	2153	2336	2471	2583	2255	2447	2588	<b>2706</b>
	kW	<b>1640</b>	1780	1882	<b>1968</b>	1496	1623	1717	1795	1722	1869	1977	2066	1804	1958	2070	<b>2165</b>
<b>LSA 51.2 L70</b>	kVA	<b>2160</b>	2344	2479	<b>2590</b>	1970	2138	2261	2362	2268	2461	2603	2720	2376	2578	2727	<b>2849</b>
	kW	<b>1728</b>	1875	1983	<b>2072</b>	1576	1710	1809	1890	1814	1969	2082	2176	1901	2062	2182	<b>2279</b>
<b>LSA 51.2 VL85</b>	kVA	<b>2250</b>	2442	2583	<b>2700</b>	2052	2227	2355	2462	2363	2564	2712	2835	2475	2686	2841	<b>2970</b>
	kW	<b>1800</b>	1954	2066	<b>2160</b>	1642	1782	1884	1970	1890	2051	2170	2268	1980	2149	2273	<b>2376</b>

Δ\* : Consult factory

## Efficiencies 50 Hz - P.F. : 1 / P.F. : 0,8

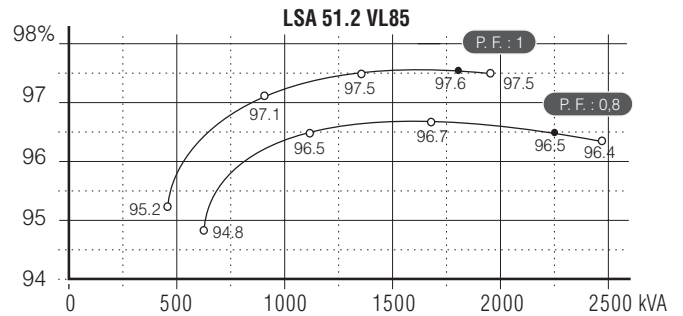
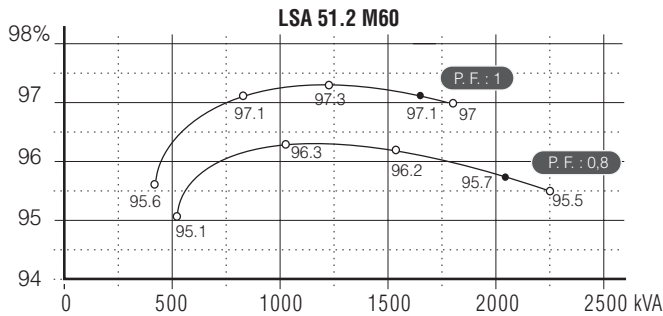
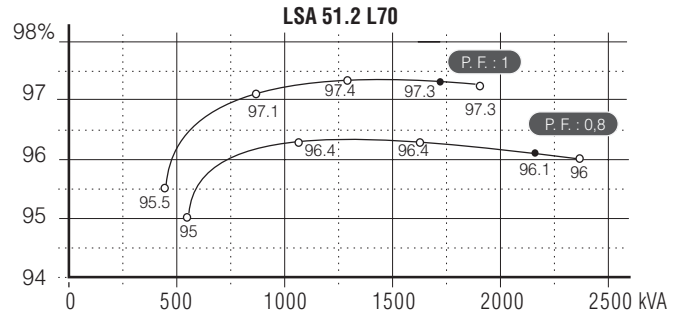
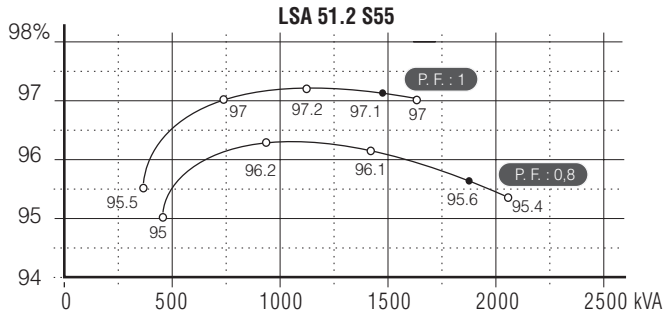

## Reactances (%) . Time constants (ms) - Class H / 400 V

	S55	M60	L70	VL85
<b>Kcc</b> Short-circuit ratio	0.33	0.35	0.39	0.45
<b>Xd</b> Direct axis synchro.reactance unsaturated	374	357	321	278
<b>Xq</b> Quadra. axis synchr.reactance unsaturated	224	214	193	167
<b>T'do</b> Open circuit time constant	2660	2770	2910	3050
<b>X'd</b> Direct axis transient reactance saturated	28.4	26.8	23.9	20.4
<b>T'd</b> Short-Circuit transient time constant	237	245	254	263
<b>X''d</b> Direct axis subtransient reactance saturated	14.8	14	12.5	10.6
<b>T''d</b> Subtransient time constant	22	23	24	26
<b>X''q</b> Quadra. axis subtransient reactance saturated	18.5	17.5	15.6	13.3
<b>Xo</b> Zero sequence reactance unsaturated	3.5	3.3	2.9	2.5
<b>X2</b> Negative sequence reactance saturated	16.6	15.7	14	12
<b>Ta</b> Armature time constant	39	41	45	49

## Other data - Class H / 400 V

	S55	M60	L70	VL85
<b>io (A)</b> No load excitation current	1.3	1.4	1.3	1.4
<b>ic (A)</b> Full load excitation current	5.6	5.5	5.2	4.6
<b>uc (V)</b> Full load excitation voltage	64	63	59	52
<b>ms</b> Recovery time ( $\Delta U = 20\%$ trans.)	700	700	700	700
<b>kVA</b> Motor start. ( $\Delta U = 20\%$ sust.) or ( $\Delta U = 50\%$ trans.)	3720	4100	4320	4500
<b>%</b> Transient dip (rated step load) - PF : 0,8 LAG	14.5	13.9	12.5	10.9
<b>W</b> No load losses	15300	16600	18200	20400
<b>W</b> Heat rejection	68000	73000	70000	65000

**Transient voltage variation 400V - 50 Hz**

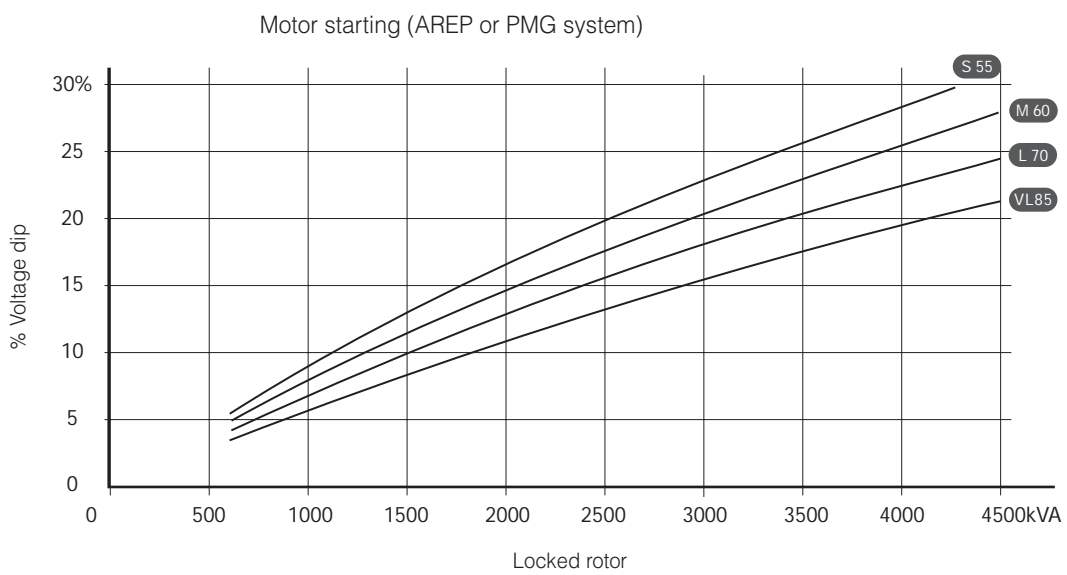
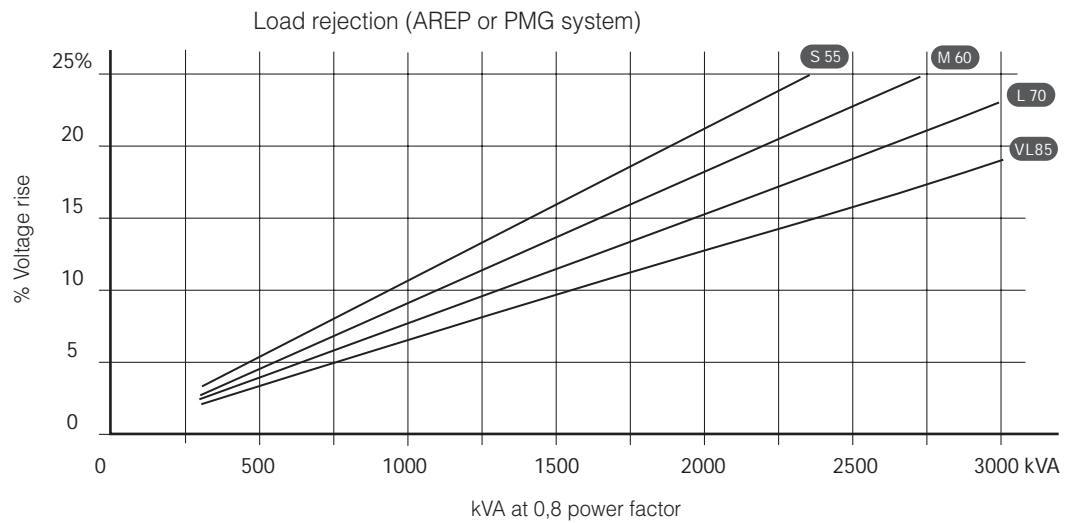
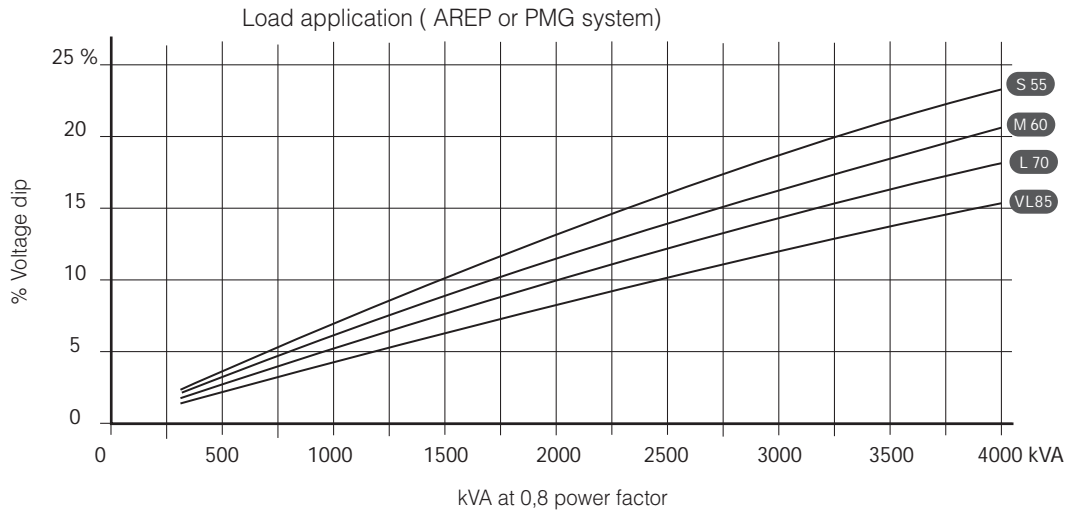

- 1 ) For a starting P.F. differing from 0,6, the starting kVA must be multiplied by  $(\text{Sine } \varnothing / 0,8)$
- 2 ) For voltages other than 400 V (Y) , 230 V ( Δ) at 50 Hz , then kVA must be multiplied by  $(400/U)^2$  ou  $(230/U)^2$  .

## Efficiencies 60 Hz - P. F. : 1 / P. F. : 0,8

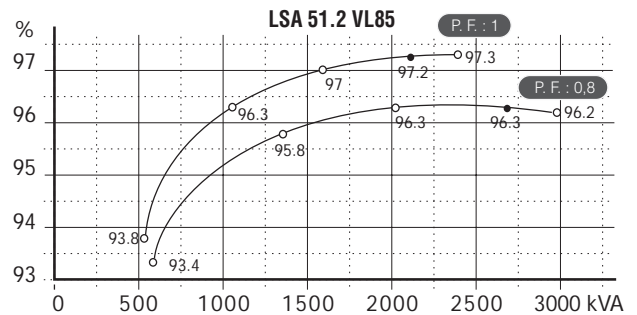
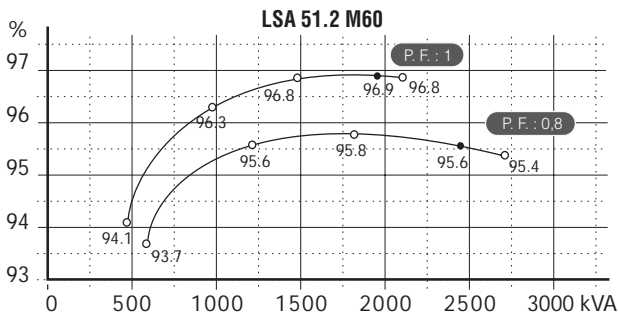
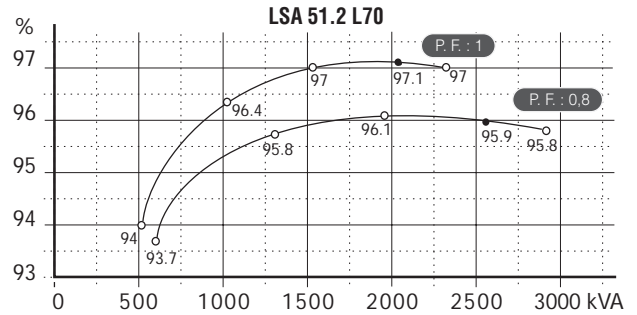
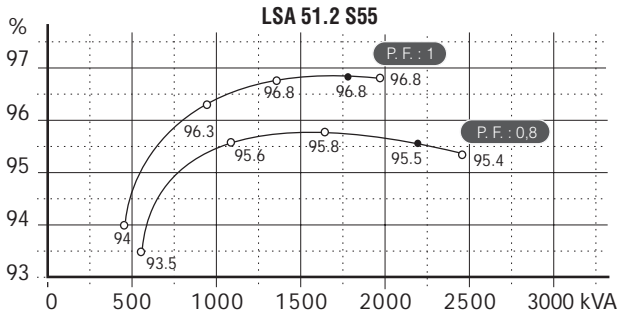

## Reactances (%) . Time constants (ms) - Class H / 480 V

	S55	M60	L70	VL85
<b>Kcc</b> Short-circuit ratio	0.33	0.35	0.39	0.45
<b>Xd</b> Direct axis synchro.reactance unsaturated	374	357	321	278
<b>Xq</b> Quadra. axis synchr.reactance unsaturated	224	214	193	167
<b>T'do</b> Open circuit time constant	2660	2770	2910	3050
<b>X'd</b> Direct axis transient reactance saturated	28.3	26.8	23.9	20.4
<b>T'd</b> Short circuit transient time constant	237	245	254	263
<b>X''d</b> Direct axis subtransient reactance saturated	14.8	14	12.4	10.6
<b>T''d</b> Subtransient time constant	22	23	24	26
<b>X''q</b> Quadra. axis subtransient reactance saturated	18.4	17.5	15.6	13.3
<b>Xo</b> Zero sequence reactance unsaturated	3.5	3.3	2.9	2.5
<b>X2</b> Negative sequence reactance saturated	16.6	15.7	14	12
<b>Ta</b> Armature time constant	39	41	45	49

## Other data - Class H / 480 V

<b>io (A)</b> No load excitation current	1.3	1.4	1.3	1.4
<b>ic (A)</b> Full load excitation current	5.6	5.5	5.2	4.6
<b>uc (V)</b> Full load excitation voltage	64	63	59	52
<b>ms</b> Recovery time ( $\Delta U = 20\%$ trans.)	700	700	700	700
<b>kVA</b> Motor start. ( $\Delta U = 20\%$ sust.) or ( $\Delta U = 50\%$ trans.)	4460	4920	5180	5400
<b>%</b> Transient dip (rated step load) - PF : 0,8 LAG	14.5	13.9	12.5	10.9
<b>W</b> No load losses	27100	28800	31100	34200
<b>W</b> Heat rejection	83000	91000	89000	82000

## Transient voltage variation 480V - 60 Hz

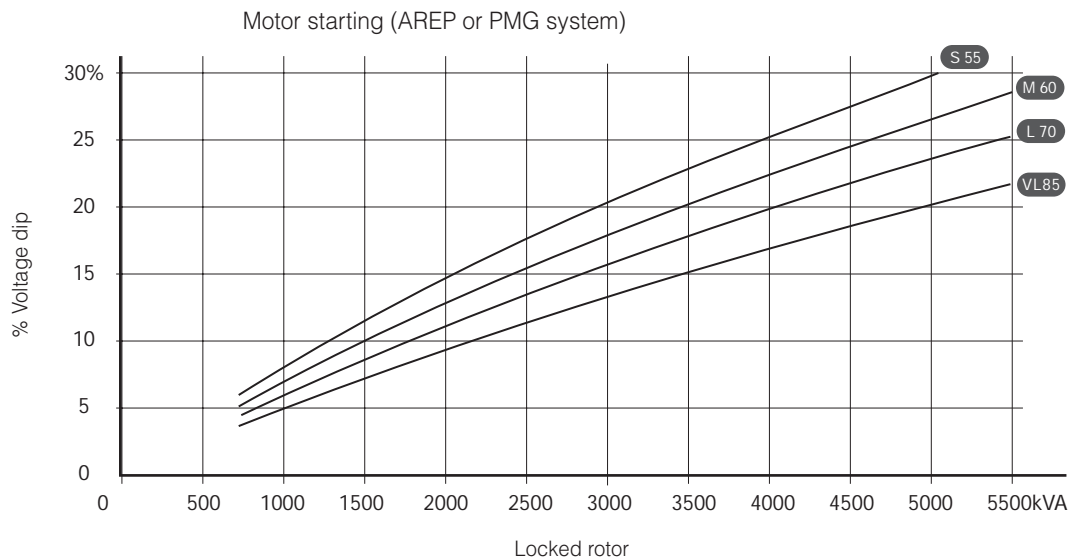
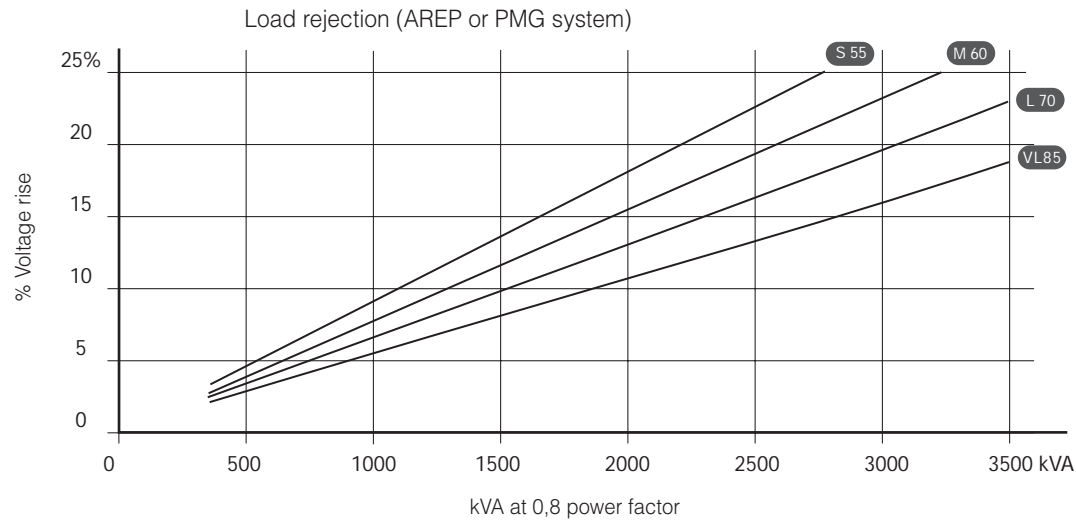
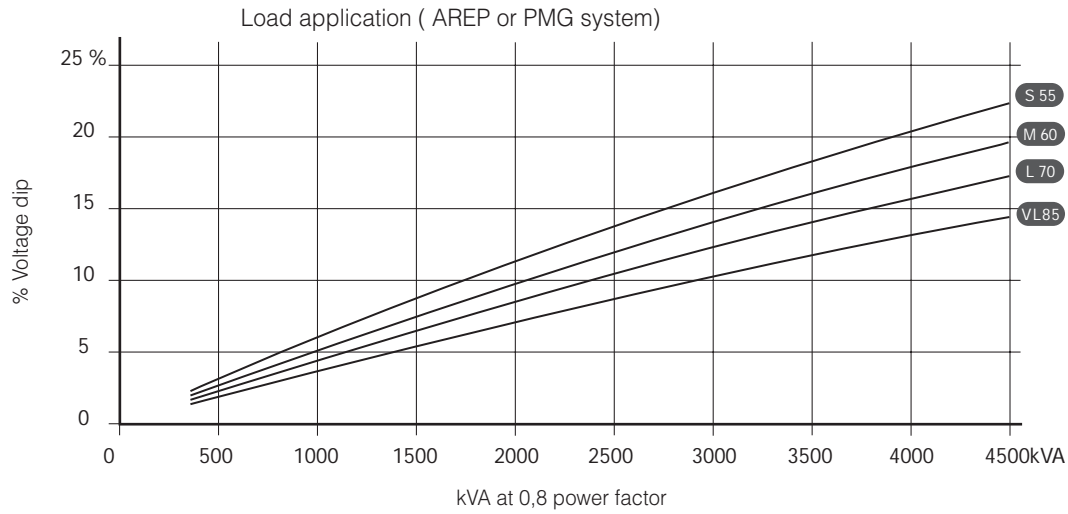

- 1 ) For a starting P.F. other than 0,6 , the starting kVA must be multiplied by  $(\text{Sine } \varnothing / 0,8 )$ .
- 2 ) For voltages other than 480 V (Y) , 277 V (Δ) , 240 V (YY) at 60 Hz , then, kVA must be multiplied by  $(480 / U)^2$  or  $(277 / U)^2$  or  $(240/U)^2$ .

**3 Phase short-circuit curves at no load and rated speed (star connection Y)**

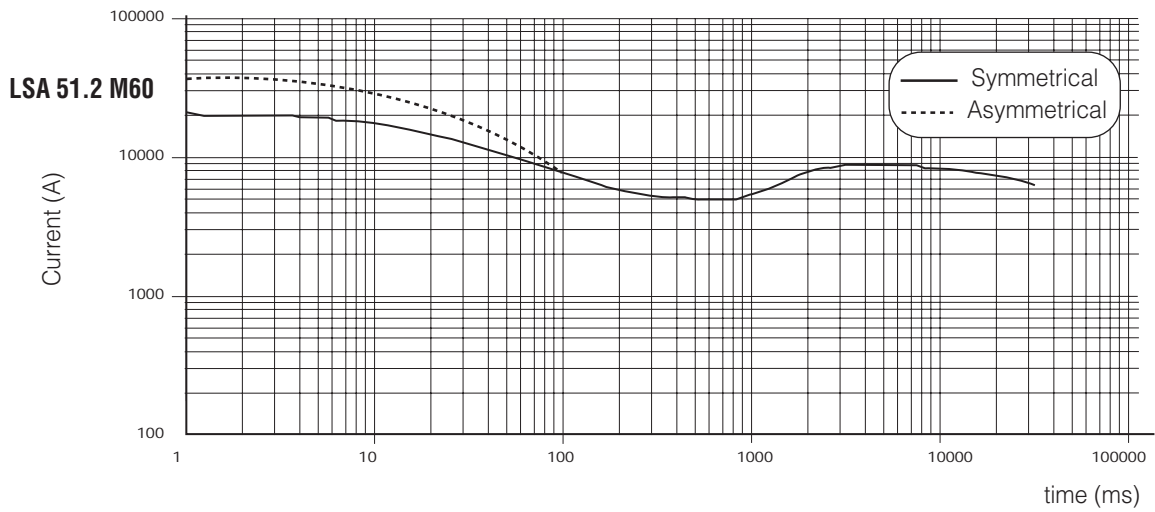
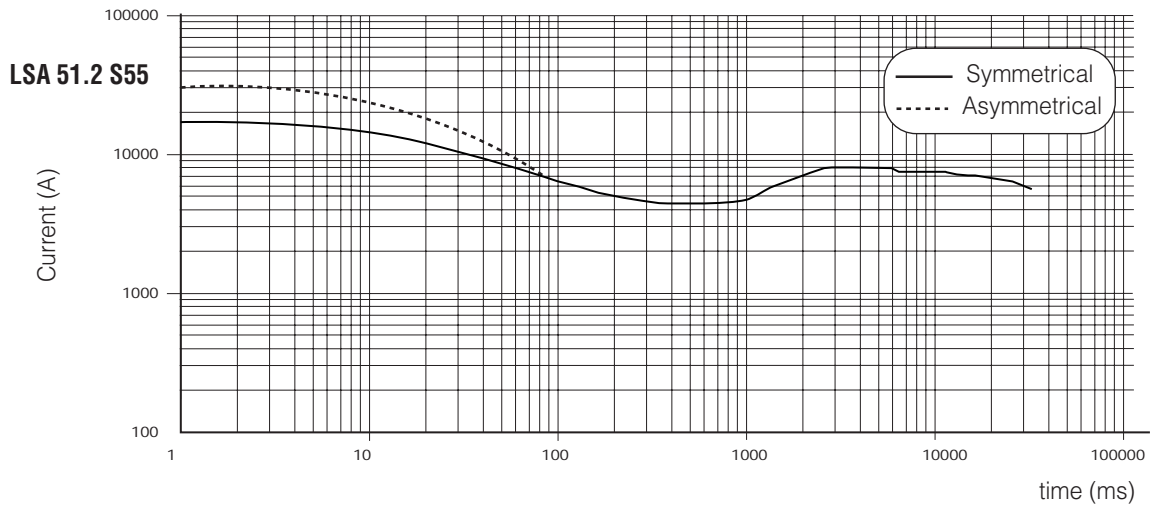

**Influence due to connexion**

Curves shown are for star connection (Y).

For other connections, use the following multiplication factors :

- Series delta : Current value x 1,732
- Parallel star : Current value x 2



**3 Phase short-circuit curves at no load and rated speed (star connection Y)**

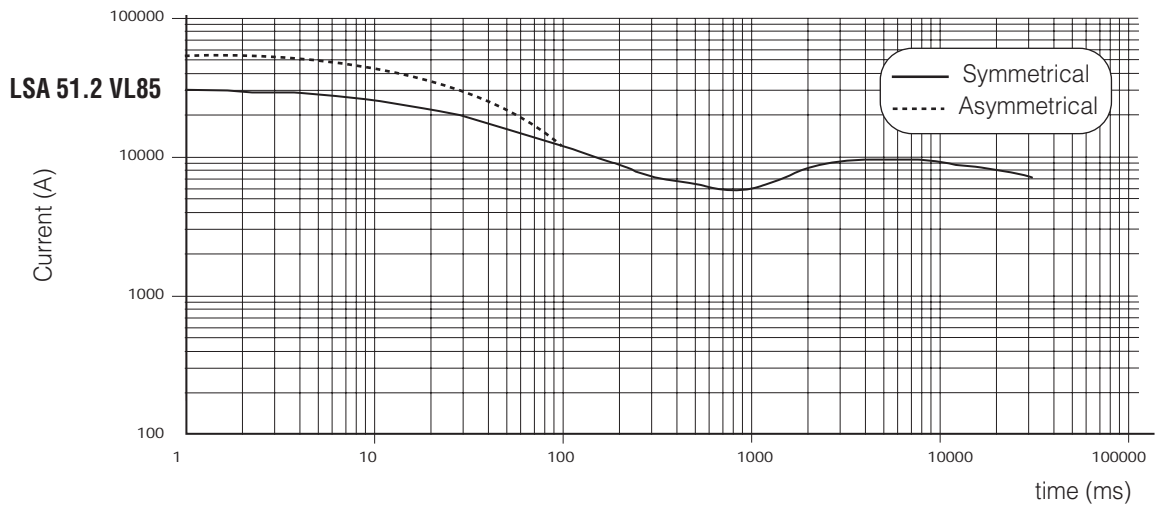
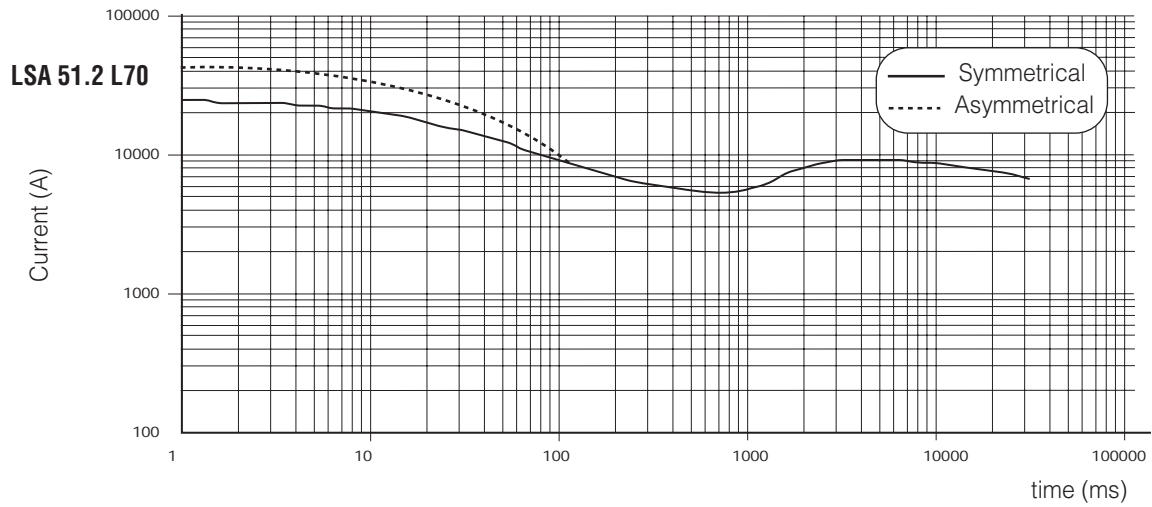

**Influence due to short-circuit.**

Curves are based on a three-phase short-circuit.

For other types of short-circuit, use the following multiplication factors :

	<b>3 phase</b>	<b>2 phase L - L.</b>	<b>1 phase L - N.</b>
<b>Instantaneous (Max)</b>	1	0,87	1,3
<b>Sustained</b>	1	1,5	2,2
<b>Max sustained duration (AREP/ PMG)</b>	10 sec.	5 sec.	2 sec.

## Single bearing dimensions

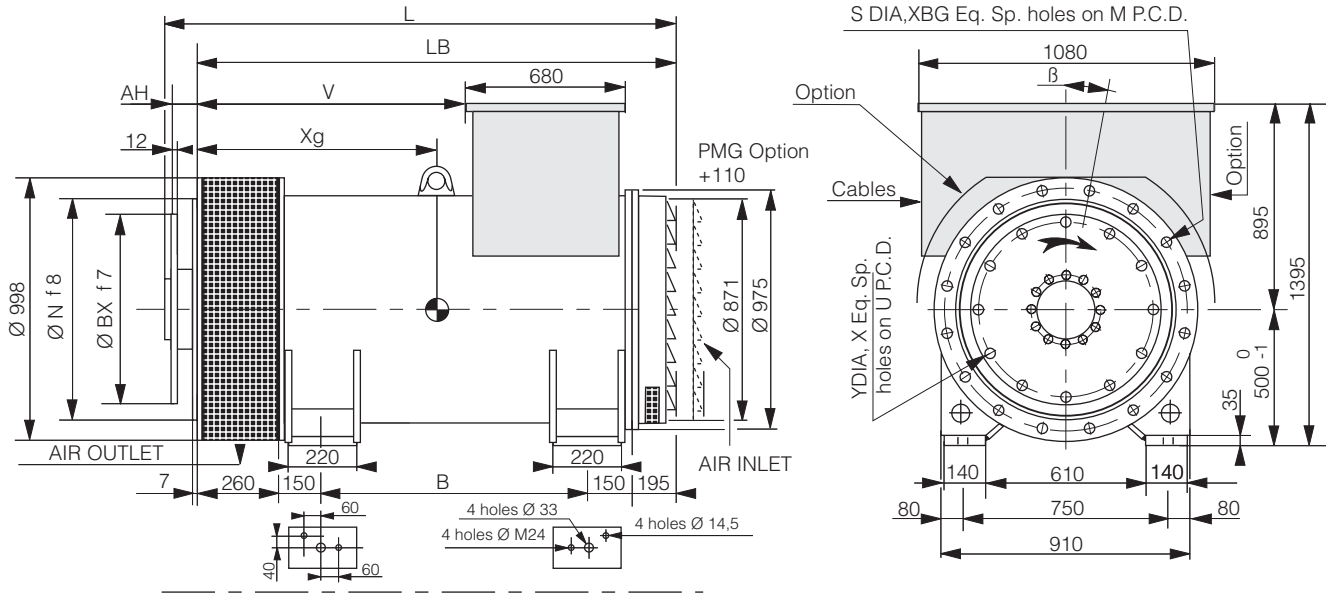

Frame dimensions (mm) and weight (kg)						
TYPE	L without PMG	LB	B	V	Xg	Weight (kg)
LSA 51.2 S55	1677	1655	900	744	735	3745
LSA 51.2 M60	1777	1755	1000	844	770	4040
LSA 51.2 L70	1877	1855	1100	944	825	4445
LSA 51.2 VL85	1977	1955	1200	1044	885	4995

Coupling		
Flex plate	0	00
Flange S.A.E 24		X
Flange S.A.E 21		X
Flange S.A.E 18	X	X

Flange dimensions (mm)					
S.A.E.	N	M	XBG	S	β
0	647.7	679.5	16	14	11° 15'
00	787.4	850.9	16	14	11° 15'

Flex plate dimensions (mm)					
S.A.E.	BX	U	X	Y	AH
24	733.4	692.1	12	21	0
21	673.1	641.3	12	18	0
18	571.5	542.9	6	18	15.8

## Torsional analysis data

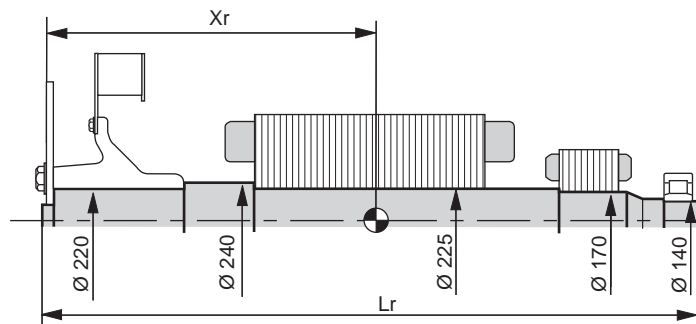

Centre of gravity : Xr (mm), rotor length Lr (mm), Weight : M (kg), Moment of inertia : J (kgm <sup>2</sup> ) : (4J = MD <sup>2</sup> )												
TYPE	Flex plate S.A.E. 18				Flex plate S.A.E. 21				Flex plate S.A.E. 24			
	Xr	Lr	M	J	Xr	Lr	M	J	Xr	Lr	M	J
LSA 51.2 S55	661	1555.5	1357	41.1	643	1555.5	1359	41.9	640	1555.5	1365	42.6
LSA 51.2 M60	703	1655.5	1475	44.8	685	1655.5	1479	45.6	682	1655.5	1483	46.3
LSA 51.2 L70	754	1755.5	1630	50	736	1755.5	1632	50.8	734	1755.5	1638	51.6
LSA 51.2 VL85	819	1855.5	1833	57.2	801	1855.5	1835	58	799	1855.5	1841	58.8

**Two bearing dimensions**

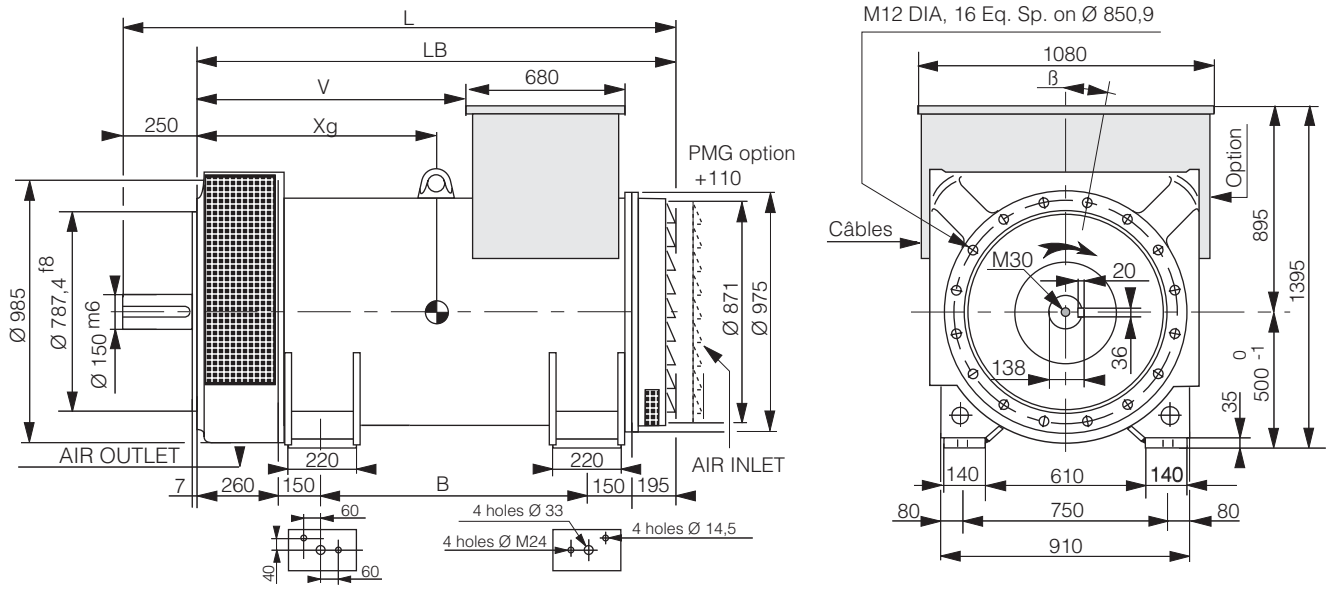

**Frame dimensions (mm) and weight (kg)**

TYPE	L without PMG	LB	B	V	Xg	Weight (kg)
LSA 51.2 S55	1905	1655	900	744	735	3725
LSA 51.2 M60	2005	1755	1000	844	770	4020
LSA 51.2 L70	2105	1855	1100	944	825	4425
LSA 51.2 VL85	2205	1955	1200	1044	885	4975

**Torsional analysis data**

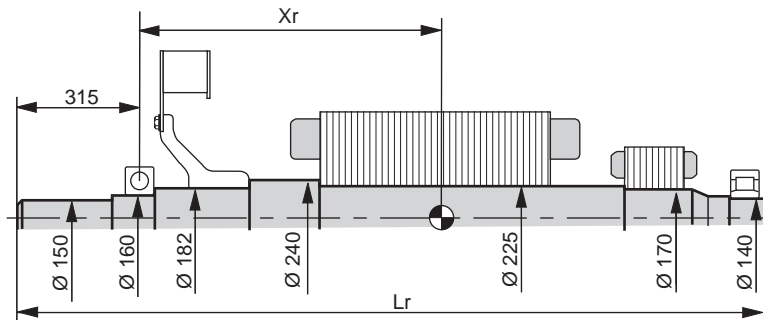

**Centre of gravity : Xr (mm), rotor length Lr (mm), Weight : M (kg), Moment of inertia : J (kgm<sup>2</sup>) : (4J = MD<sup>2</sup>)**

TYPE	Xr	Lr	M	J
LSA 51.2 S55	610.8	1783.5	1279	38.9
LSA 51.2 M60	652.6	1883.5	1396	42.6
LSA 51.2 L70	703.7	1983.5	1551	47.8
LSA 51.2 VL85	765.5	2083.5	1753	55.1



**MOTEURS LEROY-SOMER 16015 ANGOULÊME CEDEX - FRANCE**

338 567 258 RCS ANGOULÊME  
S.A. au capital de 62 779 000 ₣

*[www.leroy-somer.com](http://www.leroy-somer.com)*